

COMBIVERT

CE

GB

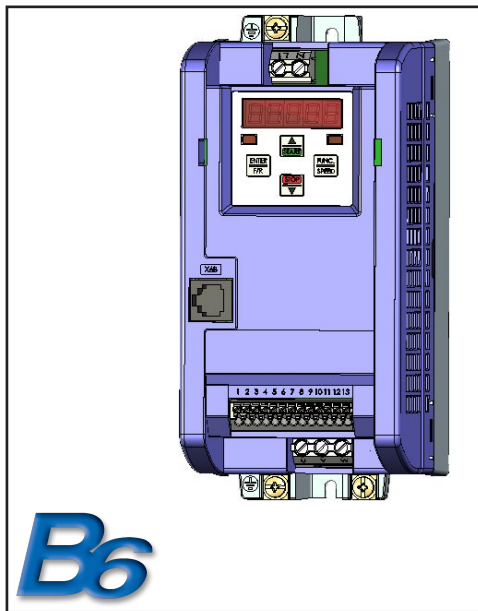

B6

Installation Manual

Housing A

GB

This manual describes the KEB COMBIVERT B6. Particular attention is paid to the installation, the connection as well as the basic operation. Due to the various application and programming possibilities, the application-specific connection and/or wiring diagram, the parameter adjustment as well as instructions to the start-up are to be taken from the documentation of the machine manufacturer.

A list of instruction manuals and documents giving assistance for the construction, documentation and service is provided at the end of this manual. The safety and warning notes listed in this instruction manual as well as in other documentation must be observed at any rate to ensure a safe operation. The safety and warning instructions specified in this manual do not lay claim on completeness. KEB reserves the right to change/adapt specifications and technical data without prior notice. The used pictograms have following significance:



Danger
Warning
Caution



Attention
observe at
all costs



Information
Aide
Tip

The information contained in the technical documentation, as well as any user-specific advice in spoken and written and through tests, are made to best of our knowledge and information about the application. However, they are considered for information only without responsibility. This also applies to any violation of industrial property rights of a third-party.

Inspection of our units in view of their suitability for the intended use must be done generally by the user. Inspections are particularly necessary, if changes are executed, which serve for the further development or adaption of our products to the applications (hardware, software or download lists). Inspections must be repeated completely, even if only parts of hardware, software or download lists are modified.

Application and use of our units in the target products is outside of our control and therefore lies exclusively in the area of responsibility of the user.

1. Safety and Operating Instructions	6
2. Product description	7
2.1 Intended use.....	7
2.2 Unit identification.....	7
2.3 Technical data.....	8
2.3.1 230 V class.....	8
2.3.2 400 V class.....	9
2.4 Dimensions and Terminals.....	10
3. Installation and Connection	11
3.1 Control cabinet installation.....	11
3.2 EMC-conform Installation.....	11
3.3 Connection of power circuit.....	12
3.3.1 Mains connection.....	12
3.3.2 Wiring instructions.....	12
3.3.3 Motor connection.....	13
3.3.4 Connection braking resistor (only 400 V class).....	13
3.4 Control board (default).....	14
3.4.1 X2A Control terminal strip.....	14
3.4.2 Connection of the control terminal strip.....	15
3.5 Control board (CAN).....	16
3.5.1 X2A Control Terminal Strip.....	16
3.5.2 Connection of the control terminal strip.....	17
4 Operation of the Unit	18
4.1 Overview of the operating elements.....	18
4.2 Keyboard Operation.....	18
4.2.1 Parameter numbers and values.....	18
4.2.2 Resetting error messages.....	18
4.2.3 Password input CP.0.....	19
4.2.4 Drive Mode.....	20
5. Parameter Description	21
6. Certifications	27
6.1 CE-Marking.....	27
6.2 UL / CUL - Marking.....	27
7. Additional Manuals	28

1. Safety and Operating Instructions



Safety and Operating Instructions for drive converters

(in conformity with the Low-Voltage Directive 73/23/EWG)

1. General

In operation, drive converters, depending on their degree of protection, may have live, uninsulated, and possibly also moving or rotating parts, as well as hot surfaces.

In case of inadmissible removal of the required covers, of improper use, wrong installation or maloperation, there is the danger of serious personal injury and damage to property.

For further information, see documentation.

All operations serving transport, installation and commissioning as well as maintenance are to be carried out by skilled technical personnel (Observe IEC 364 or CENELEC HD 384 or DIN VDE 0100 and IEC 664 or DIN/VDE 0110 and national accident prevention rules!).

For the purposes of these basic safety instructions, „skilled technical personnel“ means persons who are familiar with the installation, mounting, commissioning and operation of the product and have the qualifications needed for the performance of their functions.

2. Intended use

Drive converters are components designed for inclusion in electrical installations or machinery.

In case of installation in machinery, commissioning of the drive converter (i.e. the starting of normal operation) is prohibited until the machinery has been proved to conform to the provisions of the directive 89/392/EEC (Machinery Safety Directive - MSD). Account is to be taken of EN 60204.

Commissioning (i.e. the starting of normal operation) is admissible only where conformity with the EMC directive (89/336/EEC) has been established.

The drive converters meet the requirements of the Low-Voltage directive 73/23/EEC. They are subject to the harmonized standards of the series DIN EN 50178/VDE 0160 in conjunction with EN 60439-1/ VDE 0660, part 500, and EN 60146/ VDE 0558.

The technical data as well as information concerning the supply conditions shall be taken from the rating plate and from the documentation and shall be strictly observed.

3. Transport, storage

The instructions for transport, storage and proper use shall be complied with.

The climatic conditions shall be in conformity with EN 50178.

4 Installation

The installation and cooling of the appliances shall be in accordance with the specifications in the pertinent documentation.

The drive converters shall be protected against excessive strains. In particular, no components must be bent or isolating distances altered in the course of transportation or handling. No contact shall be made with electronic components and contacts.

Drive converters contain electrostatic sensitive components which are liable to damage through improper use. Electric components must not be mechanically damaged or destroyed (potential health risks).

5. Electrical connection

When working on live drive converters, the applicable national accident prevention rules (e.g. VBG 4) must be complied with.

The electrical installation shall be carried out in accordance with the relevant requirements (e.g. cross-sectional areas of conductors, fusing, PE connection). For further information, see documentation.

Instructions for the installation in accordance with EMC requirements, like screening, earthing, location of filters and wiring, are contained in the drive converter documentation. They must always be complied with, also for drive converters bearing a CE marking. Observance of the limit values required by EMC law is the responsibility of the manufacturer of the installation or machine.

6. Operation

Installations which include drive converters shall be equipped with additional control and protective devices in accordance with the relevant applicable safety requirements, e.g. act respecting technical equipment, accident prevention rules etc.. Changes to the drive converters by means of the operating software are admissible.

After disconnection of the drive converter from the voltage supply, live appliance parts and power terminals must not be touched immediately because of possibly energized capacitors. In this respect, the corresponding signs and markings on the drive converter must be respected.

During operation, all covers and doors shall be kept closed.

7. Maintenance and servicing

The manufacturer's documentation shall be followed.

KEEP SAFETY INSTRUCTIONS IN A SAFE PLACE!

2. Product description

2.1 Intended use

The frequency inverter KEB COMBIVERT B6 serves exclusively for the control and regulation of asynchronous motors. The operation of other electric consumers is prohibited and can lead to the destruction of the unit.

Frequency inverter are components which are intended for the installation in electric systems or machines.

2.2 Unit identification

07	B6	A	2	A	6	9	0	0	
Cooling									
0: Heat sink 1: Flat rear									
reserved									
Switching frequency; short time current limit; overcurrent limit									
8: 2 kHz; 180 %; 216 % A: 8 kHz; 180 %; 216 %									
9: 4 kHz; 180 %; 216 %									
Input identification									
6: 1-phase 230V AC									
9: 3-phase 400V AC									
Housing type A									
Accessories									
2: internal Filter									
Control type									
A: Standard B: CAN									
Series B6									
Inverter size									

Product description

2.3 Technical data

2.3.1 230 V class

Inverter size		05	07
Housing size		A	
Phases		1	
Output rated power	[kVA]	0.9	1.6
Max. rated motor power	[kW]	0.37	0.75
Output rated current	[A]	2.3	4
Max. short time current	[A]	4.1	7.2
OC-tripping current	[A]	4.9	8.6
Input rated current	[A]	4.6	8
Max. permissible mains fuse (inert)	[A]	16	16
Rated switching frequency	[kHz]	8	4
Max. switching frequency	[kHz]	8	4
Power loss at nominal operating	[W]	30	55
Mains voltage U_N	[V]	180...260 \pm 0	
Mains frequency	[Hz]	50...60 \pm 2	
Input rated voltage	[V]	230	
Output voltage	[V]	3 x 0... U_N	
Output frequency	[Hz]	0...400	
Min. motor line cross section	[mm ²]	1.5	1.5
Max. motor line length (shielded)	[m]	30 at limit value class A	
		10 at limit value class B	
For use in USA			
Max. mains fuse type RK5	[A]	10	15
Max. input fusing MMC type "E"	1) [A]	10	16

1) see 400 V class

i Site altitude maximal 2000 m above sea level. With site altitudes over 1000 m a derating of 1% per 100 m must be taken into consideration.

2.3.2 400V class

Inverter size		07	09
Housing size		A	
Phases		3	
Output rated power	[kVA]	1.8	2.8
Max. rated motor power	[kW]	0.75	1.5
Output rated current	[A]	2.6	4.1
Max. short time current	[A]	3.9	6.1
OC-tripping current	[A]	6.2	9.8
Input rated current	[A]	3.6	6
Max. permissible mains fuse (inert)	[A]	16	16
Rated switching frequency	[kHz]	4	4
Max. switching frequency	[kHz]	4	4
Power loss at nominal operating	[W]	50	80
Mains voltage U_N	[V]	305...500 ± 0	
Mains frequency	[Hz]	50...60 ± 2	
Input rated voltage	1) [V]	400	
Output voltage	[V]	3 x 0... U_N	
Output frequency	[Hz]	0...400	
Min. motor line cross section	[mm ²]	1.5	1.5
Max. motor line length (shielded)	[m]	30 at limit value class A	
For use in USA			
Max. mains fuse type RK5	[A]	6	10
Max. input fusing MMC type "E"	2) [A]	10	10

1) At mains voltage >460 V multiply the nominal current with factor 0.86

2) Use E-MMC/ Type E - Manual Motor Controller according to UL508 / Class NKJH only. The following types are accepted:

Manufacturer	UL - File	Type	Required terminal line adaptor
Siemens	E 156943	3RV1021-1xA10	3RV1928-1H
		3RV1031-4xA10	-
ABB Stotz	E 195536	MS325-xx	S3-M3
		MS450-xx	-
Rockwell / Allen Bradley	E 205542	140M-C2E-Bxx or Cxx	-
		140M-F8E-Cxx	-
Moeller	E 123500	PKZM0-xxE (only up to 25A)	BK25/3 - PKZ0-E

Where x or xx means that here current rating or letter for current rating is given.
Use only in mains Wye 480/277 V. Delta grounding is not permitted.

Product description

2.4 Dimensions and Terminals

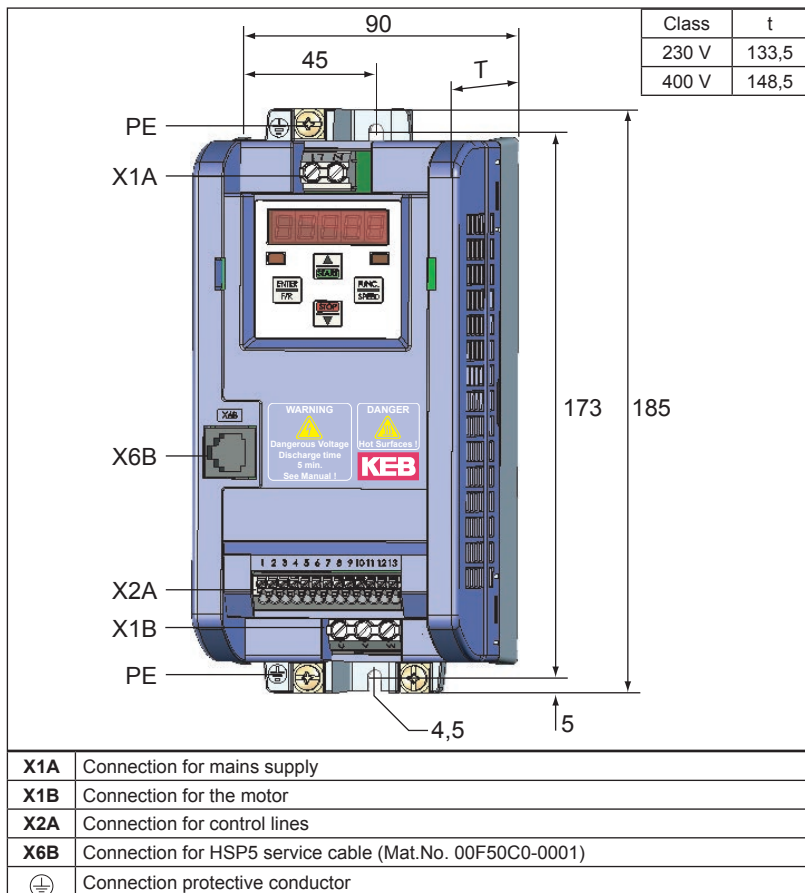

3. Installation and Connection

3.1 Control cabinet installation

Protective system (EN 60529)	IP20
Operation temperature	-10...40 °C (14...104 °F)
Storage temperature	-25...70 °C (-13...158 °F)
Max. heat sink temperature	90 °C (194 °F)
Climatic category (EN60721-3-3)	3K3
Environment (IEC 664-1)	Pollution degree 2
Vibration/Jolt according to	German. Lloyd; EN50155

The flat-rear design (projected) requires cooling measures by the machine builder. This can be in the best case no further measure at all (e.g. at cyclic operation with down times) up to the dissipation of the entire, indicated heat loss at rated operation.



The COMBIVERT must be protected against aggressive gases, aerosols and conductive dust!

Installation position and min. distances

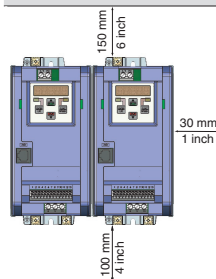

3.2 EMC-conform Installation

- Always apply the shielding of motor and control cables over a large contact surface on both sides.
- Distance between control and power cables at least 10...20 cm (4...8 inch).
- Lay motor and power cable separately.
- If it cannot be avoided, cross control and power cables in a right angle.
- Install all cables as close as possible to the mounting plate - ideal in a metal cable duct.
- Mount COMBIVERT well conducting with the mounting plate. Remove the paint beforehand.

You can find further instructions regarding the EMC-conform wiring in the Internet at KEB.

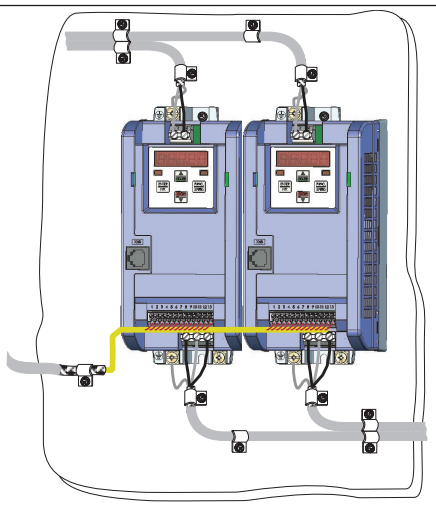

Installation and Connection

3.3 Connection of power circuit

3.3.1 Mains connection

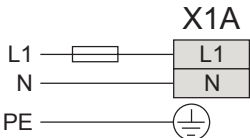
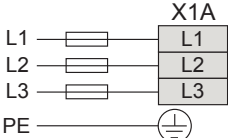
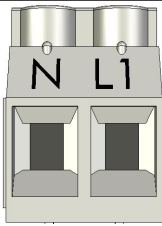
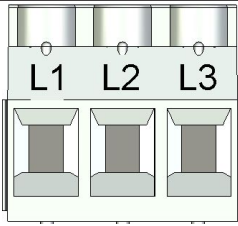
Mains connection 230 V 1-phase	Mains connection 400 V 3-phase
	
	
Terminal strip X1A / 230V class Mains voltage 180...260VAC / 1-phase	Terminal strip X1A / 400V class Mains voltage 305...500 VAC / 3-phase
Protection	
Protection (see „Technical data“) or power protective switch	
1-phase inverter RCD type A or type B	3-phase inverter RCMA with separator or RCD type B
Connection cross-section 1,5...4 mm ² (AWG 16-11) Tightening torque 0,6Nm	

3.3.2 Wiring instructions



Absolutely observe the connecting voltage of the KEB COMBIVERT. A 230V-unit will be immediately destructed on a 400V-power supply.



Never exchange the mains and motor cables.



Some countries demand that the PE-terminal is directly connected to the terminal box (not over the mounting plate).

3.3.3 Motor connection

	Max. motor line length see „Technical data“
Apply shieldings over a large contact surface of the mounting plate	
Terminal strip X1B	
Tightening torque 0,6Nm	
Connection cross-section 1,5...4 mm ² (AWG 16-11)	

3.3.4 Connection braking resistor (only 400 V class)

Terminal strip X1C	
Tightening torque 0,6Nm	
Connection cross-section 1,5...4 mm ² (AWG 16-11)	
Using shielded, twisted cables	

Installation and Connection

3.4 Control board xxB6Axx-xxxx (default)

3.4.1 X2A Control terminal strip

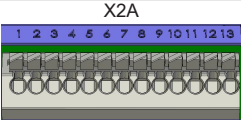
<ul style="list-style-type: none"> Conductor cross section AWG 20-16 rigidly or flexibly Wire-end ferrule without plastic case Wire-end ferrule with plastic case Strip length Use shielded/drilled cables Lay shield on one side of the inverter onto earth potential 	0.5...1.5 mm ² 0.5...1 mm ² 0.5 mm ² 8 mm	
--	---	---

PIN	Function	Name	Description
Analog input and output			
1	Analog output	AO1	Output of the actual output frequency 0...100 Hz => 0...10 VDC (max. 10 mA) Ri = 100 Ω; Resolution 11 Bit
2	Analog input	AN1+	Setpoint input resolution 10 Bit (reversible with CP.35) 0...10 VDC; Ri = 29 kΩ (factory setting) 0...20 mA, 4...20 mA; Ri = 500 Ω
Voltage supply			
3	Mass	COM	Mass for analog and digital inputs/outputs
4	+15V output	+15 V	Stabilized supply voltage for digital inputs and setpoint poti +15 VDC ±8 % / max. 50 mA Observe input voltage of analog input!
Programmable digital inputs 13...30 VDC ±0 % smoothed; Ri: 2.2 kΩ; scan time: ≤10 ms			
5	Control release / Reset	ST	Power modules are enabled; reset at opening
6	Forward	F	Rotation selection
7	Reverse	R	Forward has priority
8	Fixed frequency 1 (CP.19)	I1*)	I1 + I2 = fixed frequency 3 (CP.21)
9	Fixed frequency 2 (CP.20)	I2	
Programmable digital output 15 VDC ±10 % max. 50 mA			
10	Digital output	O1	Frequency dep. switch (factory setting) Output switches at actual frequency = setpoint frequency Programmable with CP.32
Programmable relay output max. 30 VDC / 0,01...1 A			
11	Relay 1 / NO contact	RLA	Fault signalling relay (factory setting) Programmable with CP.33
12	Relay1 / NC contact	RLB	
13	Relay1 / switching contact	RLC	

*) I1 can be changed in the application mode to a scan time of 2 ms.

Installation and Connection

3.5 Control board xxB6Bxx-xxxx (CAN)

3.5.1 X2A Control Terminal Strip

- Conductor cross section AWG 20-16 rigidly or flexibly
Wire-end ferrule without plastic case 0.5...1.5mm²
Wire-end ferrule with plastic case 0.5...1mm²
- Strip length 8mm 0.5mm²
- Use shielded / drilled cables
- Lay shield on one side of the inverter onto earth potential

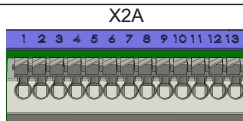

PIN	Function	Name	Description
CAN interfaces			
1	CAN high	CAN-H	Input and output of the CAN bus are parallel connected to the corresponding terminals high and low.
2	CAN low	CAN-L	
Voltage supply			
3	Mass	COM	Mass for digital inputs/outputs
4	+15V output	+15 V	Stabilized supply voltage for digital inputs and setpoint poti +15VDC $\pm 8\%$ / max. 50mA Observe input voltage of analog input!
Programmable digital inputs 13...30VDC $\pm 0\%$ smoothed; Ri: 2,2k Ω ; scan time: ≤ 10 ms			
5	Control release / Reset	ST	Power modules are enabled; reset at opening
CAN interfaces			
6	CAN shielding	CAN	Connection for shielding of the bus cables.
7	-reserved-	-	
8	-reserved-	-	
9	-reserved-	-	
Programmable digital output 15VDC $\pm 10\%$ max. 50mA			
10	Digital output	O1	Frequency dep. switch (factory setting) Output switches at actual frequency = setpoint frequency Programmable with CP.32
Programmable relay output max. 30VDC / 0.01...1A			
11	Relay 1 / NO contact	RLA	Fault signalling relay (factory setting) Programmable with CP.33
12	Relay1 / NC contact	RLB	
13	Relay1 / switching contact	RLC	

3.5.2 Connection of the control terminal strip

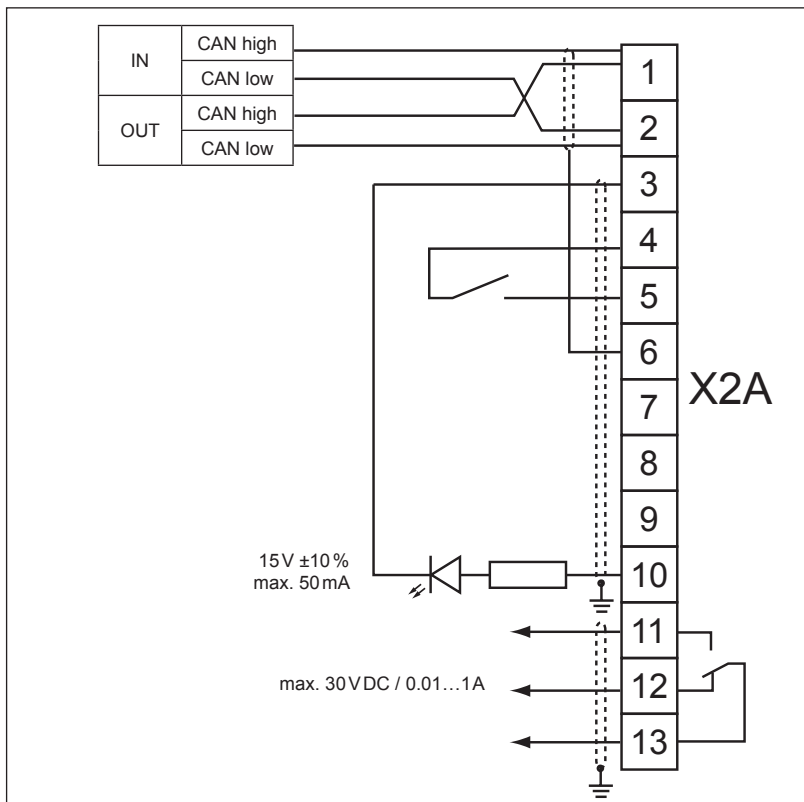

To avoid interferences a separate shielding must be provided for analog and digital control lines.
Depending on the use of the relay output, an extra shielding is to be used, too.



In case of inductive load on the relay outputs a protective wiring must be provided (e.g. free-wheeling diode)!

Operation of the Unit

4 Operation of the Unit

4.1 Overview of the operating elements

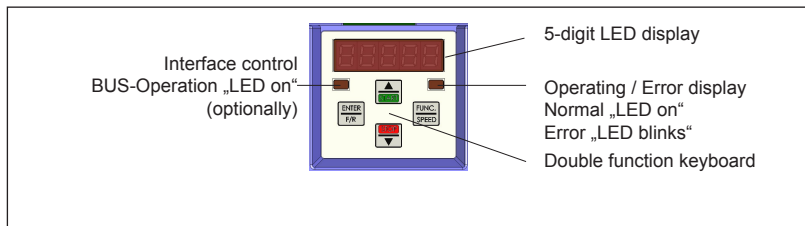

4.2 Keyboard Operation

4.2.1 Parameter numbers and values

When switching on KEB COMBIVERT B6 the value of parameter CP.1 appears.

The function key changes between the parameter value and parameter number.



With UP (▲) and DOWN (▼) the value of the parameter number is increased/decreased with changeable parameters.



Principally during a change, parameter values are immediately accepted and stored non-volatile. However, with some parameters it is not useful that the adjusted value is accepted immediately. In these cases the adjusted value is accepted and stored non-volatile by pressing ENTER. When this type of parameter is changed a point appears behind the last digit.

By pressing „ENTER“ the adjusted value is accepted and non-volatile stored.



4.2.2 Resetting error messages

If a malfunction occurs during operation, the actual display is overwritten by the alarm message. The alarm message in the display is reset by ENTER.



With ENTER only the error message in the display is reset. In order to reset the error itself, the cause must be removed or a power-on reset must be made.

4.2.3 Password input CP.0

The KEB COMBIVERT is outfitted with a comprehensive password protection. In dependence on the entered password the following modes are possible:

Display	Mode	Password ¹⁾
CP_ro	End customer menu (CP-Parameter) read-only	100
CP_on	End customer menu (CP-Parameter) read/write	200
CP_SE	Service menu (like end customer menu, but with the original parameters)	330
APPL	Application menu (all parameter groups and parameters are visible)	2)
see 4.2.4	Drive mode (COMBIVERT can be put into operation by the keyboard)	500

1) The passwords must be made unrecognizable for protection against unauthorized access.

2) The password for the application menu is described in the application manual.

The menu admissible for the application is defined by the machine builder. The password input is generally made over the parameter CP.0. The adjusted password/menu is maintained even after switching off.

Example: Changing the CP-parameter from read-only to read/write

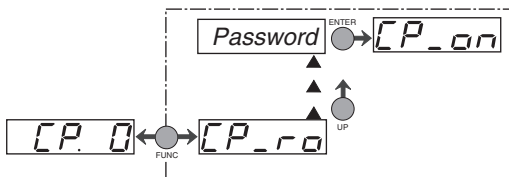

4.2.4 Drive Mode

The Drive Mode is an operating mode of KEB COMBIVERT that permits the manual starting of the drive by the keyboard. After switching the control release the set value and rotation setting are effected exclusively over the keyboard. In order to activate the drive mode the corresponding password (see 4.2.3) must be entered in CP.0. The display switches over as follows:

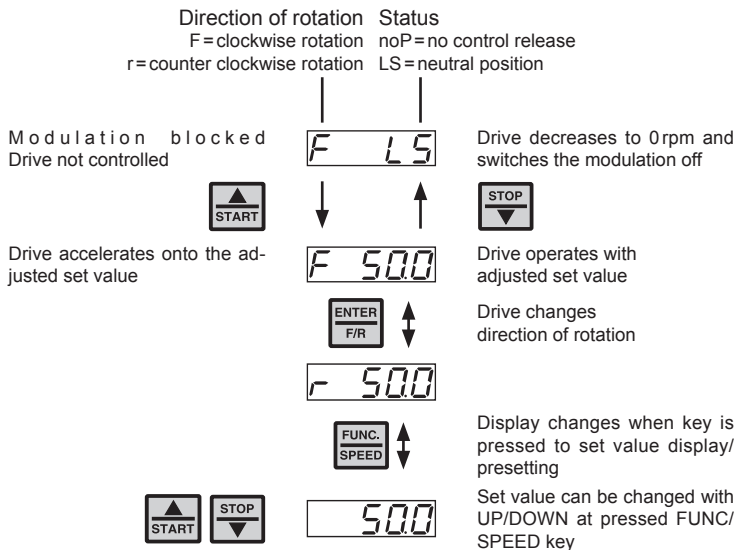

To exit the drive mode the inverter must be in status "stop" (Display noP or LS). Press the FUNC and ENTER keys simultaneously for about 3 seconds to leave the drive mode. The CP-parameters appear in the display.



5. Parameter Description

Parameter	Setting Range	Resolution	Default	Unit	↕	Based on
CP.0	Password input	0...9999	1	-	-	Ud.01
CP.1	Actual frequency display	-400...400	0.0125	0	Hz	ru.03
CP.2	Set frequency display	-400...400	0.0125	0	Hz	ru.01
CP.3	Inverter status	0...255	1	0	-	ru.00
CP.4	Apparent current	0...6553.5	0.1	0	A	ru.15
CP.5	Apparent current / peak value	0...6553.5	0.1	0	A	ru.16
CP.6	Utilization	0...65535	1	0	%	ru.13
CP.7	DC link voltage	0...1000	1	0	V	ru.18
CP.8	DC link voltage / peak value	0...1000	1	0	V	ru.19
CP.9	Output voltage	0...778	1	0	V	ru.20
CP.10	Minimal frequency	0...400	0.0125	0	Hz	oP.06
CP.11	Maximum frequency	0...400	0.0125	70	Hz	oP.10
CP.12	Acceleration time	0.00...300.00	0.01	5	s	oP.28
CP.13	Deceleration time (-0,01=CP.12)	-0.01...300.00	0.01	5	s	oP.30
CP.14	S-curve time	off ; 0.01...5.00	0.01	off	s	oP.32
CP.15	Boost	0.0...25.5	0.1	LTK	%	uF.01
CP.16	Rated frequency	0...400	0.0125	50	Hz	uF.00
CP.17	Voltage stabilization	0...649, off	1	off	V	E uF.09
CP.18	Switching frequency	0...LTK	1	LTK	-	E uF.11
CP.19	Fixed frequency 1	-400...400	0.0125	5	Hz	oP.21
CP.20	Fixed frequency 2	-400...400	0.0125	50	Hz	oP.22
CP.21	Fixed frequency 3	-400...400	0.0125	70	Hz	oP.23
CP.22	DC braking / mode	0...9	1	7	-	E Pn.28
CP.23	DC-braking / Time	0.00...100.00	0.01	10	s	Pn.30
CP.24	Max. ramp current	0...200	1	140	%	Pn.24
CP.25	Max. constant current	0...200	1	200:off	%	Pn.20
CP.26	Speed search / condition	0...15	1	8	-	E Pn.26
CP.27	Motor protection / response	0...6	1	6	-	Pn.14
CP.28	Motor protection / mode	0...1	1	1	-	dr.11
CP.29	Motor protection / rated current	0.0...370.0	0.1	LTK	A	dr.12
CP.30	Analog output / Function	0...26	1	2	-	E An.31
CP.31	Analog output / amplification	-20.00...20.00	0.01	1	-	An.33
CP.32	Transistor output / function	0...80	1	20	-	E do.00
CP.33	Relay output / function	0...80	1	4	-	E do.02
CP.34	Relay output / switching level	±30000.00	0.01	100.00	-	Le.02
CP.35	Interface Selection	0...2	1	0	-	E An.00

CP.3 Inverter status

In parameter „inverter status“ the actual operating condition of the frequency inverter is displayed. In the case of an error the current error message is displayed, even if the display has already been reset with ENTER (error-LED on the operator is still blinking).

nOP	„no Operation“; control release not bridged; modulation switched off; output voltage = 0V; drive is not controlled.
LS	„Low Speed“; no direction of rotation preset; modulation switched off; output voltage = 0V; drive is not controlled.
Facc	„Forward Acceleration“; drive accelerates with direction of rotation forward.
FdEc	„Forward Deceleration“; drive decelerates with direction of rotation forward.
rAcc	„Reverse Acceleration“; drive accelerates with direction of rotation reverse.
rdEc	„Reverse Deceleration“; drive decelerates with direction of rotation reverse.
Fcon	„Forward Constant“; drive runs with constant speed and direction of rotation forward.
rcon	„Reverse Constant“; drive runs with constant speed and direction of rotation reverse.

Status messages and information about the cause and removal are to be found in www.keb.de > [Service&Downloads](#) > [Downloads](#) ==> [Error and status messages.doc](#).

CP.17 Voltage stabilization

With this parameter a regulated output voltage in relation to the rated frequency can be adjusted. For that reason voltage variations at the input as well as in the intermediate circuit only have a small influence on the output voltage (U/f-characteristic). The function allows, among other things, an adaptation of the output voltage to special motors.

CP.22 DC braking / Mode

With DC-braking the motor is not decelerated by the ramp. Quick braking is caused by D.C. voltage, which is applied onto the motor winding. This parameter determines how the dc-braking is triggered.

Value	Activation
0	DC-braking deactivated
1	DC-braking at switch off of the direction of rotation and upon reaching 0Hz. The braking time is CP.23 or until the next direction of rotation.
2*	DC-braking as soon as setting for the direction of rotation is absent.
3*	DC-braking as soon as the direction of rotation changes or is absent.
4*	DC-braking at switch off of the direction of rotation and upon reaching 4 Hz.
5*	DC-braking when the real frequency falls below 4 Hz and the drives decelerates
6*	DC-braking as soon as the set value falls below 4 Hz.
7	reserved
8	reserved
9	DC-braking after switching on the modulation.

* Braking time depends on the actual frequency.

CP.24 Max. ramp current

This function protects the frequency inverter against switching off through overcurrent during the acceleration ramp. When the ramp reaches the adjusted value, it is stopped so long until the current decreases again. CP.3 displays "LAS" at active function.

CP.25 Max. constant current

This function protects the frequency inverter against switch off through overcurrent during constant output frequency. When exceeding the adjusted value, the output frequency is reduced until the value drops below the adjusted value. CP. 3 displays "SSL" at active function.

CP.26 Speed search condition

When connecting the frequency inverter onto a decelerating motor, an error can be triggered by the differing rotating field frequencies. With activated speed search the inverter searches for the actual motor speed, adapts its output frequency and accelerates with the adjusted ramp to the given set value. During speed search CP.3 displays "SSF". The parameter determines, under what conditions the functions operate.

In case of several conditions the sum of the value must be entered. Example: CP.26 = 12 means after reset and after auto-reset UP.

Value	Condition
0	Function off
1	at control release
2	at switch on
4	after reset
8	after Auto-Reset UP

CP.27 Motor protection / response

The motor protective function protects the connected motor against thermal destruction caused by high currents. The function corresponds largely to mechanical motor protective components, additionally the influence of the motor speed on the cooling of the motor is taken into consideration. The load of the motor is calculated from the measured apparent current (CP.04) and the adjusted rated motor current (CP.29).

For motors with separately driven fan or rated frequency of a self-ventilated motor following tripping times (VDE 0660, part 104) apply:

1,2	•	Rated current	≤	2 hours
1,5	•	Rated current	≤	2 minutes
2	•	Rated current	≤	1 minute
8	•	Rated current	≤	5 seconds

In case of failure CP.27 activates the motor protection function and adjusts the corresponding response as follows:

CP.27	Response	Description
0	Error, restart after reset Error message E.xx	Immediate switch off of modulation. Correct the error for the restart and activate reset. The prewarning changes into an error. The drive remains in the error state until a reset signal is recognized.

CP-Parameter

CP.27	Response	Description
1	Quick stopping, modulation off, restart after reset Status message A.xx	Fast stop - switch off of modulation after reaching 0Hz. Correct the error for the restart and activate reset. The drive remains in condition fast stop until a reset signal is recognized.
2	Quick stopping, holding torque, restart after reset Status message A.xx	Fast stop - holding torque on reaching 0Hz. Correct the error for the restart and activate reset. The drive remains in condition fast stop until a reset signal is recognized.
3	modulation off, automatic restart Status message A.xx	Immediate switch off of modulation; the drive returns automatically to normal operation, as soon as the fault no longer exists.
4	Quick stopping, modulation off, automatic restart Status message A.xx	Fast stop - switch off of modulation after reaching 0Hz. The drive returns automatically to normal operation, as soon as the fault no longer exists.
5	Quick stopping, holding torque, automatic restart Status message A.xx	Fast stop - holding torque on reaching 0Hz. The drive returns automatically to normal operation, as soon as the fault no longer exists.
6	Warning signal by digital output, no message	No effect on the drive. Error is being ignored. Switching conditions (CP.32 and CP.33) value „10“ are set.

CP.28 Motor protection / mode

The cooling mode of the motor is adjusted with these programmable parameters.

Value	Condition
0	Motor with separate cooling
1	Motor with self-cooling

For self-ventilated motors the tripping times decrease with the frequency of the motor (see picture). The motor protective function acts integrating, i.e. times with overload on the motor are added, times with underload are subtracted. After triggering the motor protective function, the new tripping time is reduced to 1/4 of the specified value, if the motor has not been operated for an appropriate time with underload.

CP.29 Motor protection / rated current

This parameter specifies for each set the rated current (= 100% utilization) for the motor protective function. The motor protection-load is calculated as follows:

$$\text{Motor protection load} = \frac{\text{Inverter apparent current (CP.04)}}{\text{Motor protection / rated current (CP.29)}}$$

CP.30 Analog output 1 / Function

CP.30 defines the function of analog output 1. The output at the analog output is always made in a range of 0...+10V. Negative values are inverted and the output is displayed in a positive value.

Value	Function	Scaling factor
0	Absolute actual frequency CP.1	0...100% (0...±100%)
1	absolute set frequency CP.2	0...100Hz
2	actual frequency CP.1	0...±100Hz
3	set frequency CP. 2	0...±100Hz
4	output voltage CP.9	0...500V
5	DC link voltage CP.7	0...1000V
6	apparent current CP.4	0...2 • rated current
7	active current ru.17	0...2 • ±rated current
8...10	reserved	–
11	absolute active current ru.17	0...2 • rated current
12	power stage temperature ru.38	0...100 °C
13...21	reserved	–
22	Analog input before amplification (ru.27)	0...100%
23	Analog input after amplification (ru.28)	0...400%
24...25	reserved	–
26	Active power ru.81	0...±2 • Rated power

CP.32 Transistor output / function (term. X2A.10)

The switching level of CP.32 is preset to 4,00. Value range see CP.33.

CP.33 Relay output 1 / function (terminals X2A.11...13)

The switching level of CP.33 is adjusted by CP.34.

Value	Function
0	No function (generally off)
1	Generally on
2	Run signal; also by DC-braking
3	Ready signal (no error)
4	Fault relay
5	Fault relay (without auto-reset)
6	Warning or error message at abnormal stopping
7	Overload pre-warning
11	Motor protection pre-warning
12	Cable breakage 4...20mA on analog input 1
14	max. constant current (Stall, CP.25) exceeded
15	max. ramp current (LA-Stop, CP.24) exceeded
16	DC-braking active
20	Actual value = set value (CP.3 = Fcon; rcon; not at noP, LS, error, SSF)
21	Accelerate (CP.3=FAcc, rAcc, LAS)
22	Decelerate (CP.3 = FdEc, rdEc, LdS)
23	Real direction of rotation = set direction of rotation
24	Utilization (CP.6) > switching level
25	Active current > switching level
26	Intermediate circuit voltage (CP.7) > switching level
27	Real value (CP.1) > switching level
28	Set value (CP.2) > switching level
31	Absolute set value at AN1 > switching level

34	Set value at AN1 > switching level
40	Hardware current limit activated
41	modulation on
44	Inverter status > switching level
47	Ramp output value > switching level
48	Apparent current (CP.4) > switching level
49	Forward running (not at nOP, LS, abnormal stopping or error)
50	Reverse running (not at nOP, LS, abnormal stopping or error)
63	Absolut ANOUT1 > switching level
65	ANOUT1 > switching level
73	Absolute active power > switching level
74	Active power > switching level
80	Active current > switching level

No listed values are only for application mode.

CP.35 AN1 Set value selection

The setpoint input (AN1) of the control can be triggered with different signal levels. In order to correctly evaluate the signal, this parameter must be adapted to the signal source.

Value	Set value signal
0	0...+10VDC / Ri = 29k Ω
1	0...+20mADC / Ri = 500 Ω
2	4...20mADC / Ri = 500 Ω

6. Certifications

6.1 CE-Marking

CE marked frequency inverter and servo drives were developed and manufactured to comply with the regulations of the Low-Voltage Directive 73/23/EEC.

The inverter or servo drive must not be started until it is determined that the installation complies with 89/392/EEC (machine directive) as well as the EMC-directive (89/336/EEC)(note EN60204).

The frequency inverters and servo drives meet the requirements of the Low-Voltage Directive 73/231/EEC. The harmonized standards of the series EN50178 in connection with EN60439-1 and EN60146 were used.

This is a product of limited availability in accordance with IEC61800-3. This product may cause radio interference in residential areas. In this case the operator may need to take corresponding measures.

6.2 UL / CUL - Marking



To be conform according to UL and CUL for the use on the North American and Canadian Market the following instructions must be observed:

- Inverter is suitable for use on a circuit capable of delivering not more than 10kArms (symmetrical), 240 VAC or 480 VAC maximum
- Maximum surrounding air temperature 40 °C (104 °F)
- For control cabinet mounting as „Open Type“
- For use in a pollution degree 2 environment
- Motor protection by adjustment of current parameters
- Not incorporated with overspeed protection
- Control terminal tightening torque (see chapter 3.3)
- Control terminal tightening torque (see chapter 3.4)
- Overload protection at 130% of inverter output rated current (see type plate)
- Refer to this installation instructions for proper wiring

7. Additional Manuals

You find supplementary manuals and instructions for the download under

www.keb.de > Service&Downloads > Downloads

General instructions

- Part 1 EMC-and safety instructions

Unit-specific instructions

- Part 2 Power Circuit
- Part 3 Control Circuit

Service notes

- Up- /Download of parameter lists with KEB COMBIVERT
- Error messages

Instruction and information for construction and development

- Application Manual
- Preparation of a user-defined parameter menu
- Programming of the digital inputs
- Input fuses in accordance with UL

All documents are also available in printed version, however we have to charge a nominal fee for these.



Karl E. Brinkmann GmbH

Försterweg 36-38 • D-32683 Barntrup
fon: +49 5263 401-0 • fax: +49 5263 401-116
net: www.keb.de • mail: info@keb.de

KEB Antriebstechnik GmbH & Co. KG

Wildbacher Str. 5 • D-08289 Schneeberg
fon: +49 3772 67-0 • fax: +49 3772 67-281
mail: info@keb-combidrive.de

KEB Antriebstechnik Austria GmbH

Ritzstraße 8 • A-4614 Marchtrenk
fon: +43 7243 53586-0 • fax: +43 7243 53586-21
net: www.keb.at • mail: info@keb.at

KEB Antriebstechnik

Herenveld 2 • B-9500 Geraardsbergen
fon: +32 5443 7860 • fax: +32 5443 7898
mail: vb.belgien@keb.de

KEB Power Transmission Technology (Shanghai) Co. Ltd – Office Room 401

No. 665 North Songwei Road (New Husong Road),
Songjiang District, CHN-201613 Shanghai, P.R. China
fon: +86 21 51095995 • fax: +86 21 54450115
net: www.keb.cn • mail: info@keb.cn

KEB Antriebstechnik Austria GmbH

Organizační složka
K. Weise 1675/5 • CZ-370 04 České Budějovice
fon: +420 387 699 111 • fax: +420 387 699 119
net: www.keb.cz • mail: info.keb@seznam.cz

KEB España

C/ Mitjer, Nave 8 - Pol. Ind. LA MASIA
E-08798 Sant Cugat Sesgarrigues (Barcelona)
fon: +34 93 897 0268 • fax: +34 93 899 2035
mail: vb.espana@keb.de

Société Française KEB

Z.I. de la Croix St. Nicolas • 14, rue Gustave Eiffel
F-94510 LA QUEUE EN BRIE
fon: +33 1 49620101 • fax: +33 1 45767495
net: www.keb.fr • mail: info@keb.fr

KEB (UK) Ltd.

6 Chieftain Business Park, Morris Close
Park Farm, Wellingborough GB-Northants, NN8 6 XF
fon: +44 1933 402220 • fax: +44 1933 400724
net: www.keb-uk.co.uk • mail: info@keb-uk.co.uk

KEB Italia S.r.l.

Via Newton, 2 • I-20019 Settimo Milanese (Milano)
fon: +39 02 33535311 • fax: +39 02 33500790
net: www.keb.it • mail: kebitalia@keb.it

KEB - YAMAKYU Ltd.

15-16, 2-Chome, Takanawa Minato-ku
J-Tokyo 108-0074
fon: +81 33 445-8515 • fax: +81 33 445-8215
mail: info@keb.jp

KEB Taiwan Ltd.

No.8, Lane 89, Sec.3; Taichung Kang Rd.
R.O.C.-Taichung City / Taiwan
fon: +886 4 23506488 • fax: +886 4 23501403
mail: info@keb.com.tw

KEB Korea Seoul

Room 1709, 415 Missy 2000
725 Su Seo Dong, Gang Nam Gu
ROK-135-757 Seoul/South Korea
fon: +82 2 6253 6771 • fax: +82 2 6253 6770
mail: vb.korea@keb.de

KEB Sverige

Box 265 (Bergavägen 19)
S-43093 Hälsö
fon: +46 31 961520 • fax: +46 31 961124
mail: vb.schweden@keb.de

KEB America, Inc.

5100 Valley Industrial Blvd. South
USA-Shakopee, MN 55379
fon: +1 952 224-1400 • fax: +1 952 224-1499
net: www.kebamerica.com • mail: info@kebamerica.com